

# PRORIL

60Hz

GOVOX-G Series, these vortex pumps feature a less impeller wear and longer pump life by a vortex flow that allows fibrous materials and solid matters to be pumped out without obstruction.

Sewage Pump

## GOVOX-G 322/337/437

Vortex Pump



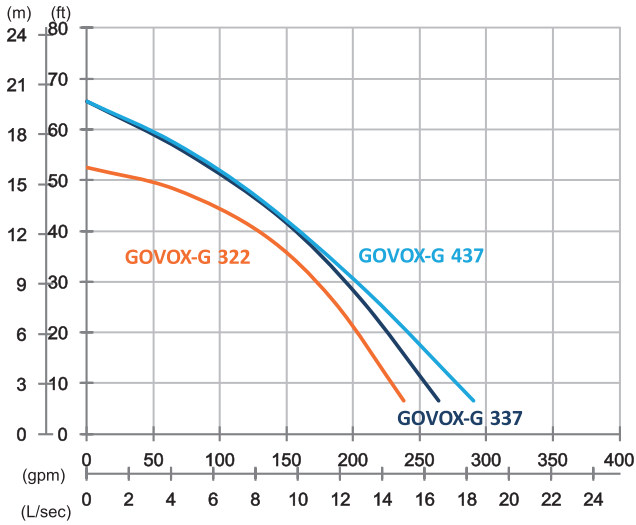

	GOVOX-G 322	GOVOX-G 337	GOVOX-G 437
<b>OUTPUT</b>	3 HP (2.2 kW)	5 HP (3.7 kW)	5 HP (3.7 kW)
<b>OUTLET</b>	3" (80 mm)	3" (80 mm)	4" (100 mm)
<b>SOLID PASSAGE</b>	1.9" (47 mm)	2" (52 mm)	2" (52 mm)
<b>Weight</b>	132 lbs/60 kg	141 lbs/64 kg	141 lbs/64 kg
<b>HEAD</b>	Rated: 39 ft, 12 m Max: 52 ft, 16 m	Rated: 43 ft, 13 m Max: 66 ft, 20 m	Rated: 46 ft, 14 m Max: 66 ft, 20 m
<b>FLOW</b>	Rated: 132 gpm, 8.3 L/s Max: 238 gpm, 15 L/s	Rated: 145 gpm, 9.2 L/s Max: 264 gpm, 16.7 L/s	Rated: 132 gpm, 8.3 L/s Max: 291 gpm, 18.3 L/s

<b>Pump Type</b>	Electric Submersible Pumps	
<b>Motor</b>	Phase	3-Phase
	Type	Induction Motor
	Poles	2 Pole (3450 rpm)
	Insulation	Class F
	Protector	Circle Thermal Protector
	Starter	D.O.L.
<b>Lubricant</b>	Food Grade (ISO VG32)	
<b>Specs.</b>	Impeller Type	Vortex
	Shaft Seal	Double Mechanical Seal Silicon Carbide VS Ceramic/Carbon
	Bearings	C3 Shielded ball bearings
	Cable	CSA-Certified PVC Jacketed Cables 33 ft (10 m) or longer upon request
<b>Materials</b>	Pump Casing	Gray Iron
	Impeller	Gray Iron
	Motor Frame	Gray Iron
	Motor Shaft	Stainless Steel
<b>Max. Liquid Temperature</b>	40°C (104°F)	
<b>Max. Submersion Depth</b>	20 m (66 ft)	
<b>pH Range</b>	pH 5 - pH 8	
<b>Guide Rail</b>	GRF-03 (322/337)/GRF-04 (437)	

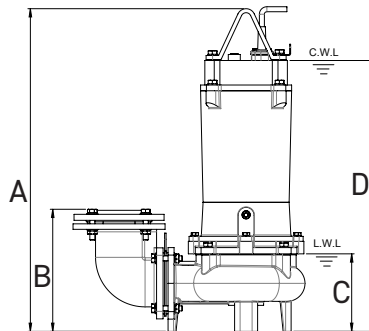
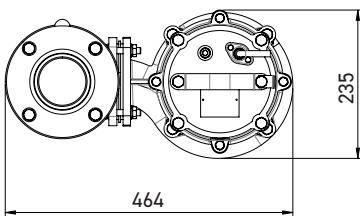

	A	B	C	D
GOVOX-G 322	645	244	155	542
GOVOX-G 337	645	244	155	542
GOVOX-G 437	645	253	153	540

unit : mm  
C.W.L : Continuous running water level  
L.W.L : Lowest running water level